

Lab Manager Case Study: Optical Networking Systems Verification Lab

The Challenges:

- > High capital equipment expenditures
- > High cost of setup, teardown, and re-setup
- > Cabling, fiber cleaning, and troubleshooting connections reducing effective test time
- > Unpredictable resource requirements resulting in net underutilization of test resources
- > Lack of 24x7 testing capability
- > Increased costs due to fixed test beds dedicated to testing specific features
- > Inability to share/leverage Agilent and Gnubi test equipment

Cisco's Optical Transport Group has some of the most automated and efficient labs in the business. This document provides an overview of the challenges faced by this group before they implemented the Lab Manager solution (see sidebar), and the benefits gained after they implemented the solution.

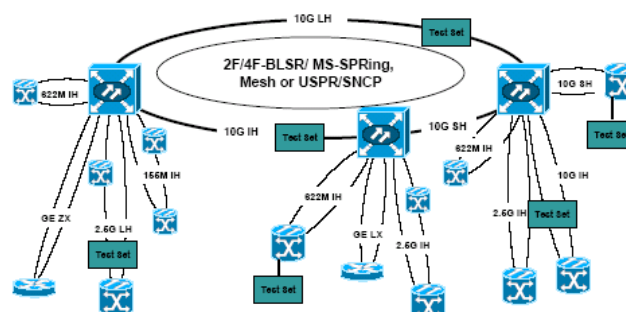

Before: Hours to connect and build test topologies

The Solution

Gale Technologies created a software-controlled architecture made up of:

Optical switching infrastructure comprising four optical switches from two different Lab Manager switch partners, totaling approximately 600 ports

Lab Manager software managing all switches and providing automated

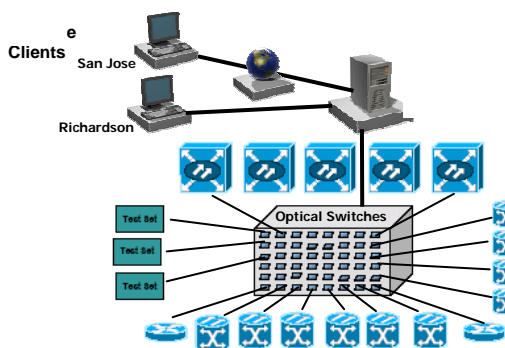

After: Topologies configured in seconds with Lab Manager

North America:

2600 San Tomas Expy
Suite 100
Santa Clara, CA 95051
T: 408.213.4900
F: 408213.4901
Email:
sales@galetechnologies.com

Europe:

London, UK
T: +44 (0) 7887 732 228
Email:
emea@galetechnologies.com

Asia:

B-73, Sector 57
Noida – 201 301
Uttar Pradesh, India
T: +91 120 2588445 48
F: +91 120 2581921
Email:
sales@galetechnologies.com

www.galetechnologies.com

Key Benefits

Instant reconfiguration of fiber topologies by one click from the Lab Manager Client

Run 100s of iterations of test cases, improving test volume and repeatability

Automatically schedule resources and test routines, making sharing of expensive resources very practical

Automatically run tests overnight

Configuration ready for tests in the morning

Remote access of the system from home or office

Transparently manage optical switches from multiple manufacturers

Improved test coverage results in increased quality and customer satisfaction

Reduced time to market

Quantitative Results

Reconfiguration that used to take hours or days now takes seconds

2 people are now able to do what used to take 6 people, allowing engineers to spend time testing instead of cabling

\$400k total investment resulted in \$600k+ annual savings

Learn More

The information provided in this document briefly describes some of the capabilities and benefits of Gale Technologies' Lab Manager. Please contact Gale via sales@galetechnologies.com for additional information, or visit us at www.galetechnologies.com.